

UNDERCOUNTER GLASSWASHERS  
GX SERIES



HOBART UK,  
SOUTHGATE WAY,  
ORTON SOUTHGATE,  
PETERBOROUGH.  
PE2 6GN  
0844 888 7777

www.hobartuk.com

Undercounter Glasswasher (Low Body)

GXCW-11B

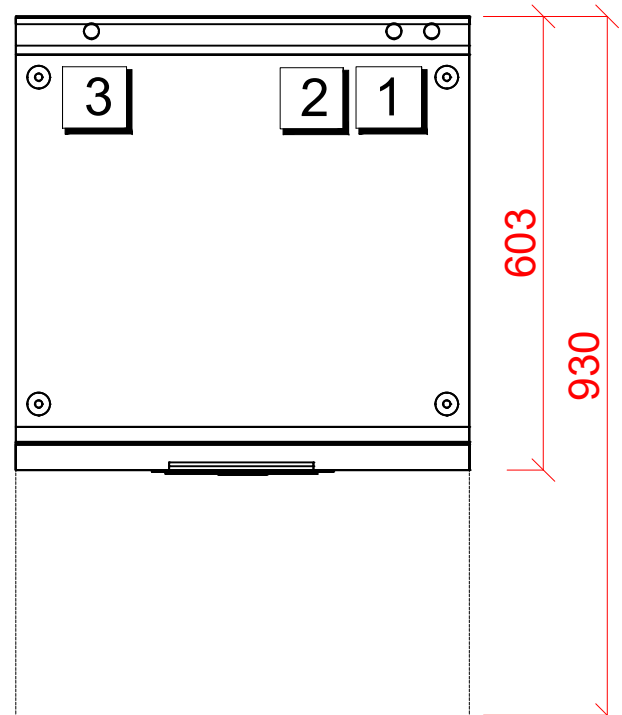
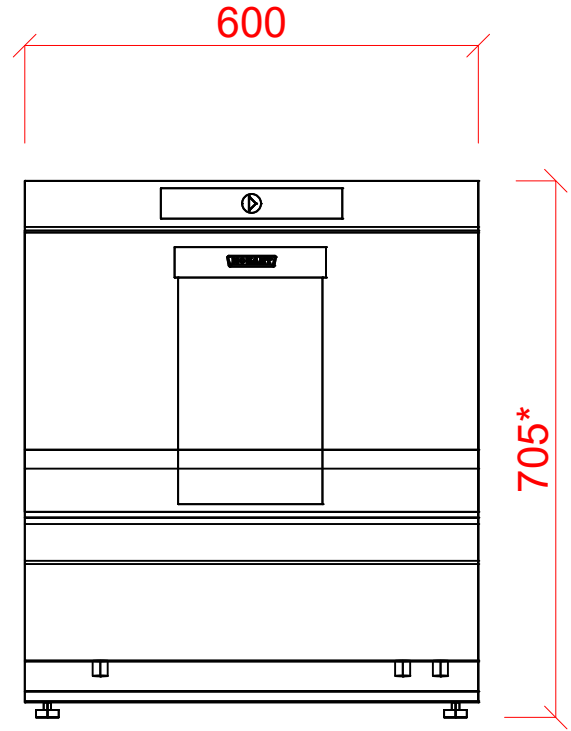
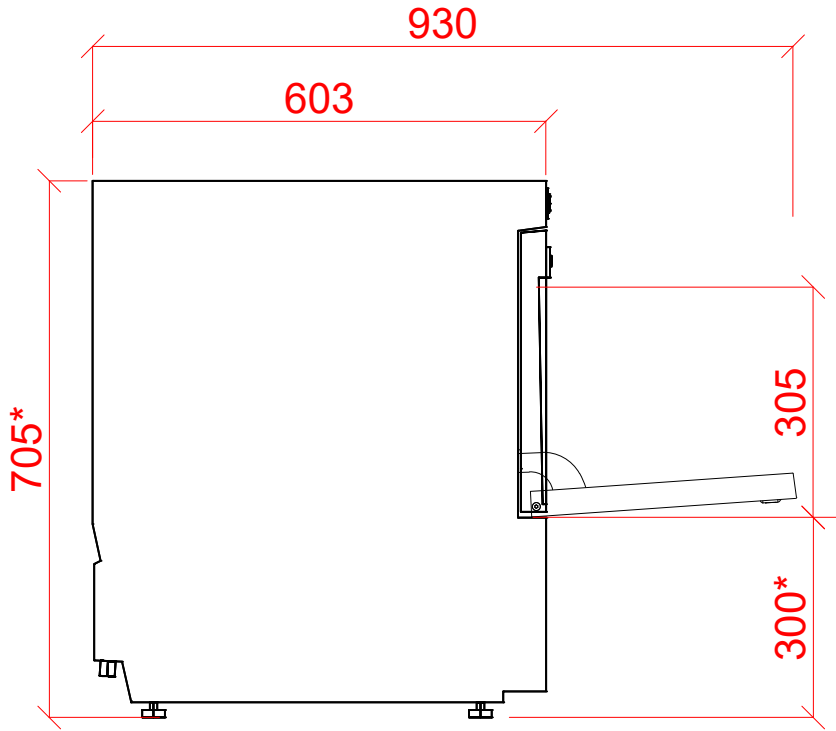

1 Water

22mm CONNECTION VIA 2 METRE FLEXIBLE HOSE, FEMALE TERMINATION.

WATER SUPPLY 10 TO 60°C (0° TO 3° CLARK MAX) @ 0.6 TO 6.0 BAR MAX. INITIAL TANK FILL 10.8 LITRES.

RINSE WATER USAGE 2.0 LITRES PER CYCLE. MAX USAGE 120 LITRES PER HOUR.

OUR MACHINES ARE SUPPLIED WITH CLASS 'AA' AIR GAP AS STANDARD.

2 Drain

DRAIN - 2 METRE FLEXIBLE HOSE TO A 40 mm TRAPPED STANDPIPE 800mm MAX A.F.F.L.

FLOW RATE 30 LITRES PER MINUTE.

Other Services

RINSE AGENT HOSE - 2.5 METRE FLEXIBLE.  
DETERGENT HOSE - 2.5 METRE FLEXIBLE.

3 Electric

6.8kW 400/50/3 + N + E FUSED AT 3 x16amps MACHINE SUPPLIED WITH 2.5 METRES OF CABLE (3 PHASE).

**CONFIGURABLE TO:**  
4.7kW 230/50/1 FUSED AT 25amps OR  
2.7kW 230/50/1 FUSED AT 13amps

Notes

APPROX WEIGHTS:  
EMPTY: 50kg's WITH WATER: 72kg's  
\* = + 40mm

PLOT SCALE: 1:10

RIGHT TO MAKE NECESSARY CHANGES IS RESERVED